

Kcal = Watt x 0.860  
BTU = Watt x 3.413

Watt  $\Delta t$  60° = Watt  $\Delta t$  50° x 1.267  
Watt  $\Delta t$  40° = Watt  $\Delta t$  50° x 0.749  
Watt  $\Delta t$  30° = Watt  $\Delta t$  50° x 0.516  
Watt  $\Delta t$  20° = Watt  $\Delta t$  50° x 0.305

p max = 10.0 bar

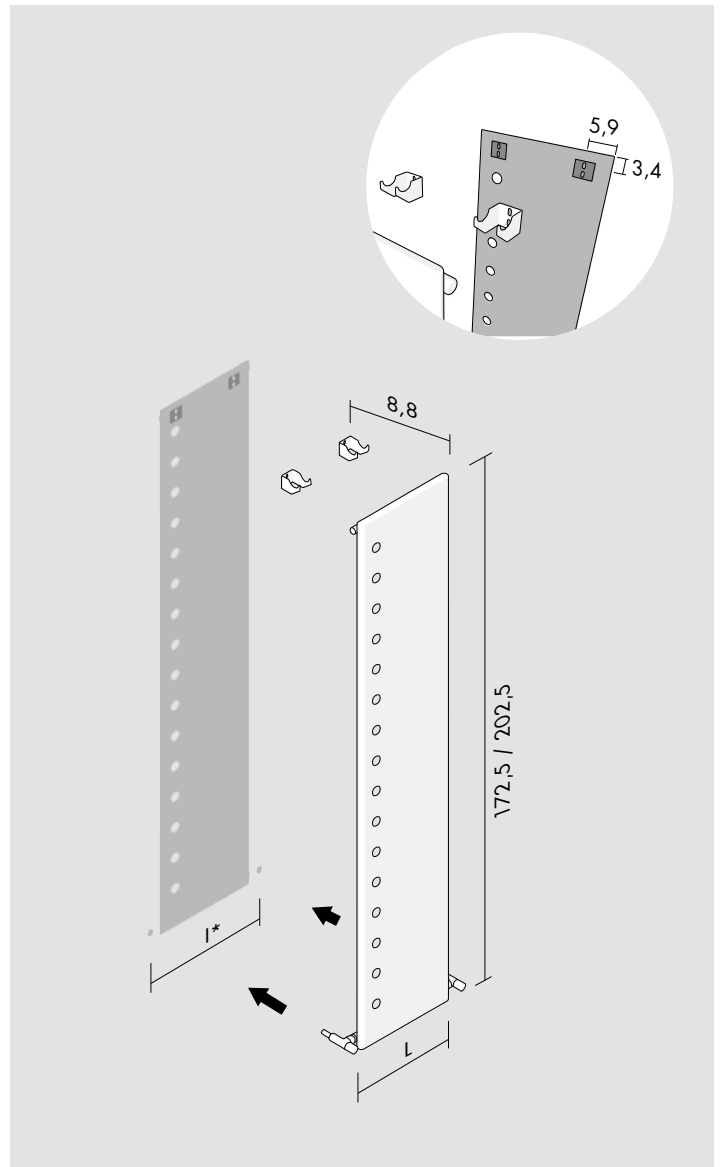

Standard connection / Raccord standard  
Standard Anschluss / Conexión estándar

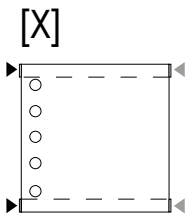

[XM\_]

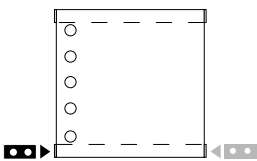

Special connection / Raccord spéciale / Speziell Anschluss / Conexión especial

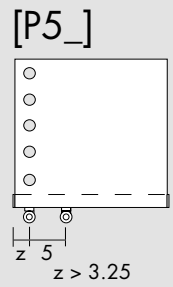
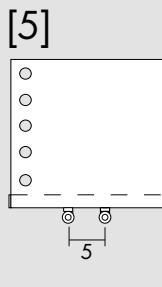
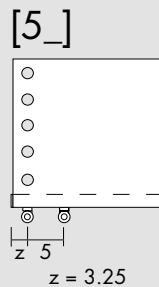
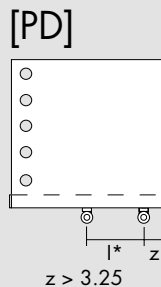
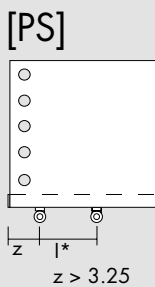
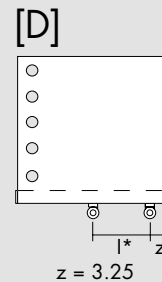
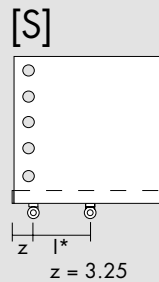
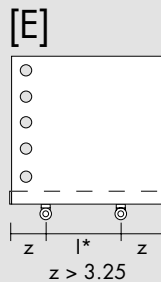
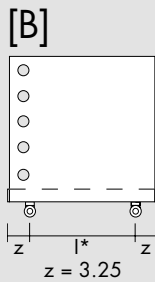

Replace \_ with connection S (Left) or D (Right). / Remplacer le \_ avec raccordement S (Gauche) ou D (Droite). / Um linker oder rechter Anschluss zu bestellen, bitte das Symbol \_ mit S (links) oder D (rechts) ersetzen. / Sustituir el \_ con las conexiones S (Izquierda) o D (Derecha).

I\* = pipe centres / distance entre depart et retour / Achsabstand / distancia entre las conexiones

### Flat VS

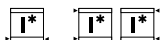

H cm	L cm	l* cm	l* cm	art*	Lt*	watt $\Delta t$ 30°	watt $\Delta t$ 50°
172.5	37.5	45.8	166.0	<b>FL13S172015</b>	2.8	309	<b>598</b>
172.5	49.5	57.8	166.0	<b>FL13S172020</b>	3.7	411	<b>797</b>
172.5	66.3	74.6	166.0	<b>FL13S172027</b>	5.0	555	<b>1 076</b>
202.5	37.5	45.8	196.0	<b>FL13S202015</b>	3.2	358	<b>694</b>
202.5	49.5	57.8	196.0	<b>FL13S202020</b>	4.2	477	<b>925</b>
202.5	66.3	74.6	196.0	<b>FL13S202027</b>	5.7	644	<b>1 249</b>

### Flat VD

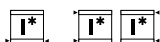

H cm	L cm	l* cm	l* cm	art*	Lt*	watt $\Delta t$ 30°	watt $\Delta t$ 50°
172.5	37.5	45.8	166.0	<b>FL13D172015</b>	5.0	463	<b>897</b>
172.5	49.5	57.8	166.0	<b>FL13D172020</b>	6.7	617	<b>1 195</b>
172.5	66.3	74.6	166.0	<b>FL13D172027</b>	9.0	833	<b>1 614</b>
202.5	37.5	45.8	196.0	<b>FL13D202015</b>	5.8	536	<b>1 038</b>
202.5	49.5	57.8	196.0	<b>FL13D202020</b>	7.7	714	<b>1 384</b>
202.5	66.3	74.6	196.0	<b>FL13D202027</b>	10.4	964	<b>1 869</b>

## Flat VS Inox

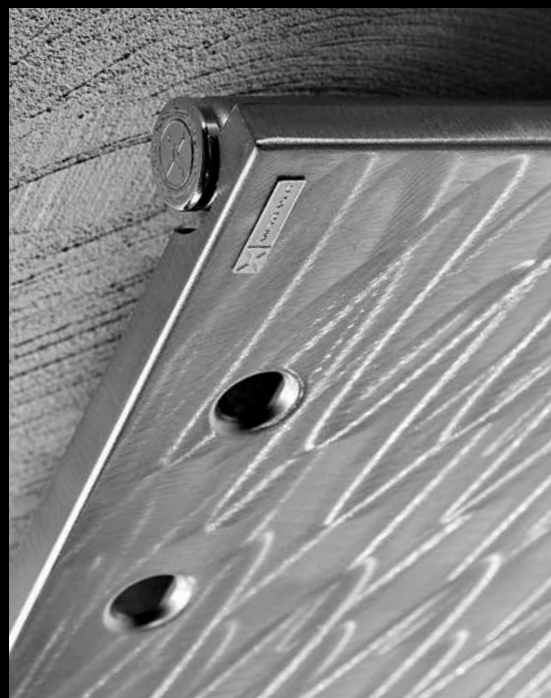

Carbon steel radiator with stainless steel plate sanded by hand  
 Radiateur en acier au carbone avec plaque en acier inoxydable poncé à la main  
 Heizkörper aus Karbonstahl mit von Hand polierter Edelstahlplatte  
 Radiador en acero al carbonio con placa inox pulida artesanalmente

H cm	L cm	l* cm	l* cm	art*	Lt*	watt $\Delta t$ 30°	watt $\Delta t$ 50°
172.5	37.5	45.8	166.0	<b>FL13S172015</b>	2.8	289	<b>560</b>
172.5	49.5	57.8	166.0	<b>FL13S172020</b>	3.7	385	<b>747</b>
172.5	66.3	74.6	166.0	<b>FL13S172027</b>	5.0	521	<b>1 009</b>
202.5	37.5	45.8	196.0	<b>FL13S202015</b>	3.2	335	<b>650</b>
202.5	49.5	57.8	196.0	<b>FL13S202020</b>	4.2	447	<b>867</b>
202.5	66.3	74.6	196.0	<b>FL13S202027</b>	5.7	604	<b>1 171</b>

## Optional



Angled Valve  
 Vanne équerre  
 Eckausführung Ventil  
 Válvula a escuadra

[BIAN] **E12SQB**  
 [CROM] **E12SQR**



Thermostatic head  
 Tête thermostatique  
 Thermostatkopf  
 Cabezal termostático

[BIAN] **VTTB**  
 [CROM] **VTTR**

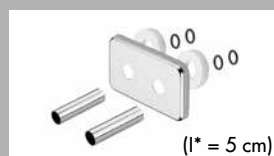

Sleeving kit  
 Kit couvre tuyau  
 Rosetten  
 Kit cubre tubo

[BIAN] **C5B**  
 [CROM] **C5R**

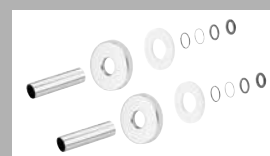

$\varnothing \leq 16$  mm  
 [BIAN] **CTB**  
 [CROM] **CTR**

$16 \text{ mm} < \varnothing < 24$  mm  
 [BIAN] **CWB**  
 [CROM] **CWR**

art\* = item / modèle / Artikel / artículo    l\* = pipe centres / distance entre depart et retour / Achsabstand / distancia entre las conexiones  
 Lt\* = water content for each element / volume d'eau pour chaque element / Wassergehalt für Element / contenido de agua por cada elemento  
 P\* = page / page / Seite / página

# Flat O

DESIGN ANDREA CROSETTA

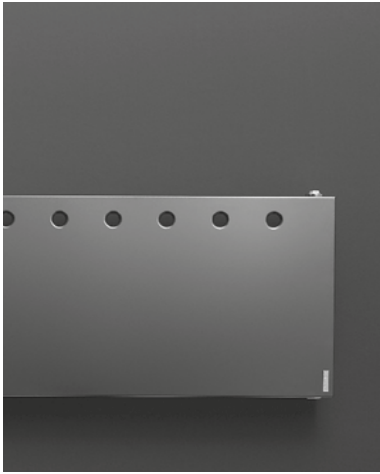
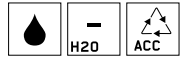

$$\text{Kcal} = \text{Watt} \times 0.860$$

$$\text{BTU} = \text{Watt} \times 3.413$$

$$\text{Watt } \Delta t 60^\circ = \text{Watt } \Delta t 50^\circ \times 1.267$$

$$\text{Watt } \Delta t 40^\circ = \text{Watt } \Delta t 50^\circ \times 0.749$$

$$\text{Watt } \Delta t 30^\circ = \text{Watt } \Delta t 50^\circ \times 0.516$$

$$\text{Watt } \Delta t 20^\circ = \text{Watt } \Delta t 50^\circ \times 0.305$$

p max = 10.0 bar

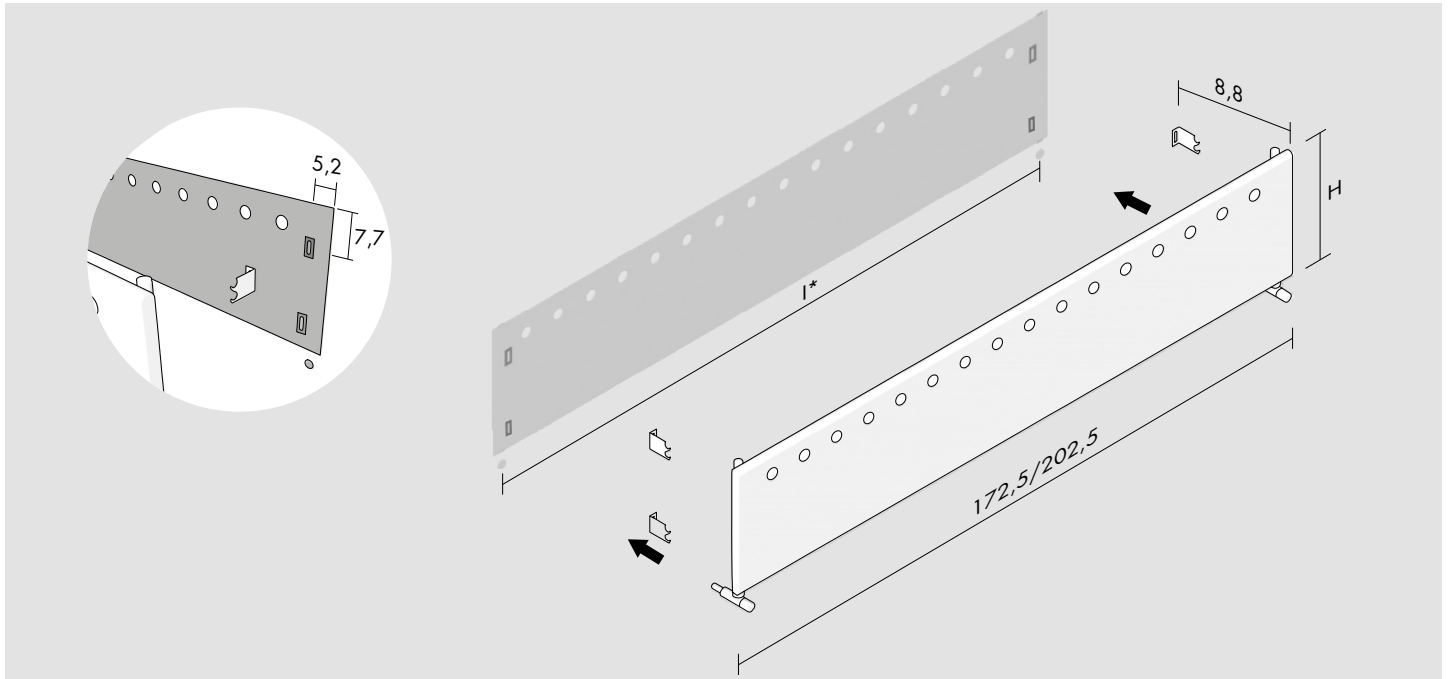

Standard connection / Raccord standard  
Standard Anschluss / Conexión estándar

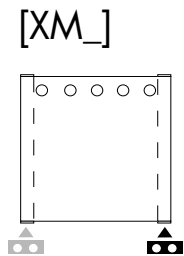
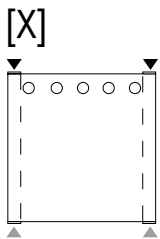

Special connection / Raccord spéciale / Speziell Anschluss / Conexión especial

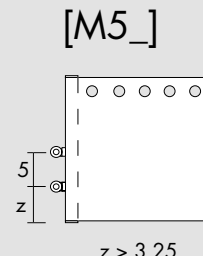
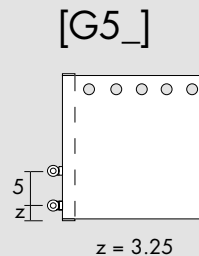
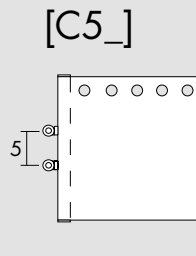
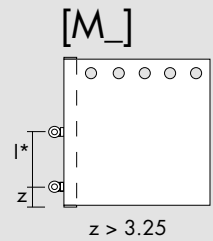
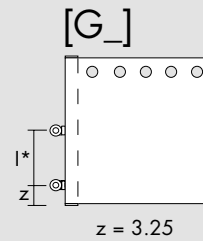
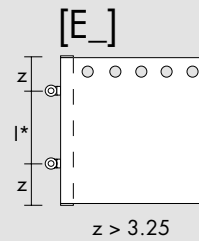
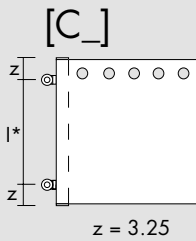

Replace \_ with connection S (Left) or D (Right). / Remplacer le \_ avec raccordement S (Gauche) ou D (Droite). / Um linker oder rechter Anschluss zu bestellen, bitte das Symbol \_ mit S (links) oder D (rechts) ersetzen. / Sustituir el \_ con las conexiones S (Izquierda) o D (Derecha).

I\* = pipe centres / distance entre depart et retour / Achsabstand / distancia entre las conexiones

## Flat OS

H cm	L cm	I* cm	I* cm	art*	Lt*	watt $\Delta t$ 30°	watt $\Delta t$ 50°
37.5	172.5	45.8	166.0	<b>FO13S172015_</b>	2.8	338	<b>655</b>
49.5	172.5	57.8	166.0	<b>FO13S172020_</b>	3.7	450	<b>873</b>
66.3	172.5	74.6	166.0	<b>FO13S172027_</b>	5.0	608	<b>1 178</b>
37.5	202.5	45.8	196.0	<b>FO13S172015_</b>	3.2	397	<b>770</b>
49.5	202.5	57.8	196.0	<b>FO13S172020_</b>	4.2	530	<b>1 027</b>
66.3	202.5	74.6	196.0	<b>FO13S172027_</b>	5.7	715	<b>1 386</b>

## Flat OD

H cm	L cm	I* cm	I* cm	art*	Lt*	watt $\Delta t$ 30°	watt $\Delta t$ 50°
37.5	172.5	45.8	166.0	<b>FO13D172015_</b>	5.0	566	<b>1 097</b>
49.5	172.5	57.8	166.0	<b>FO13D172020_</b>	6.7	774	<b>1 500</b>
66.3	172.5	74.6	166.0	<b>FO13D172027_</b>	9.0	972	<b>1 884</b>
37.5	202.5	45.8	196.0	<b>FO13D202015_</b>	5.8	666	<b>1 290</b>
49.5	202.5	57.8	196.0	<b>FO13D202020_</b>	7.7	911	<b>1 765</b>
66.3	202.5	74.6	196.0	<b>FO13D202027_</b>	10.4	1 143	<b>2 216</b>

## Flat OS Inox

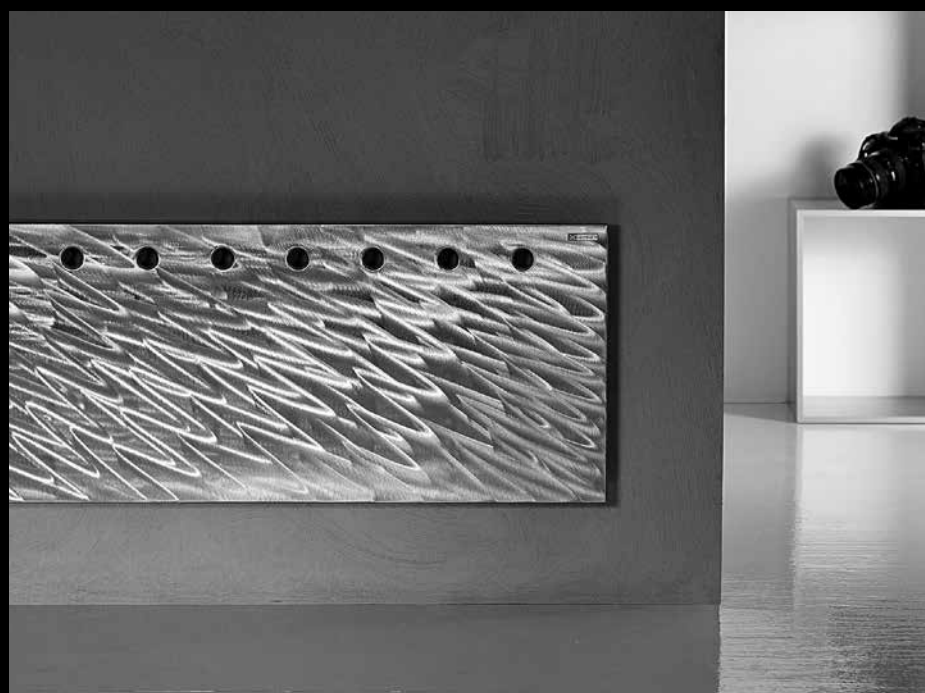

Carbon steel radiator with stainless steel plate sanded by hand

Radiateur en acier au carbone avec plaque en acier inoxydable poncé à la main

Heizkörper aus Karbonstahl mit von Hand polierter Edelstahlplatte

Radiador en acero al carbono con placa inox pulida artesanalmente

H cm	L cm	I* cm	I* cm	art*	Lt*	watt $\Delta t$ 30°	watt $\Delta t$ 50°
37.5	172.5	45.8	166.0	<b>FO13S172015_</b>	2.8	317	<b>614</b>
49.5	172.5	57.8	166.0	<b>FO13S172020_</b>	3.7	422	<b>818</b>
66.3	172.5	74.6	166.0	<b>FO13S172027_</b>	5.0	570	<b>1 105</b>
37.5	202.5	45.8	196.0	<b>FO13S172015_</b>	3.2	373	<b>722</b>
49.5	202.5	57.8	196.0	<b>FO13S172020_</b>	4.2	497	<b>963</b>
66.3	202.5	74.6	196.0	<b>FO13S172027_</b>	5.7	671	<b>1 300</b>

## Optional



Angled Valve  
 Vanne équerre  
 Eckausführung Ventil  
 Válvula a escuadra

[BIAN] **E12SQB**  
 [CROM] **E12SQR**



Thermostatic head  
 Tête thermostatique  
 Thermostatkopf  
 Cabezal termostático

[BIAN] **VTTB**  
 [CROM] **VTTR**

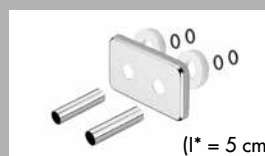

Sleeving kit  
 Kit couvre tuyau  
 Rosetten  
 Kit cubre tubo

[BIAN] **C5B**  
 [CROM] **C5R**

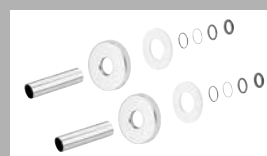

$\varnothing \leq 16$  mm  
 [BIAN] **CTB**  
 [CROM] **CTR**

$16 \text{ mm} < \varnothing < 24$  mm  
 [BIAN] **CWB**  
 [CROM] **CWR**

**art\*** = item / modèle / Artikel / artículo    **I\*** = pipe centres / distance entre depart et retour / Achsabstand / distancia entre las conexiones  
**Lt\*** = water content for each element / volume d'eau pour chaque element / Wassergehalt für Element / contenido de agua por cada elemento  
**P\*** = page / page / Seite / página